

# THROUGH CONDUIT SLAB GATE VALVE

Through Conduit Slab Gate Valves for Onshore Applications

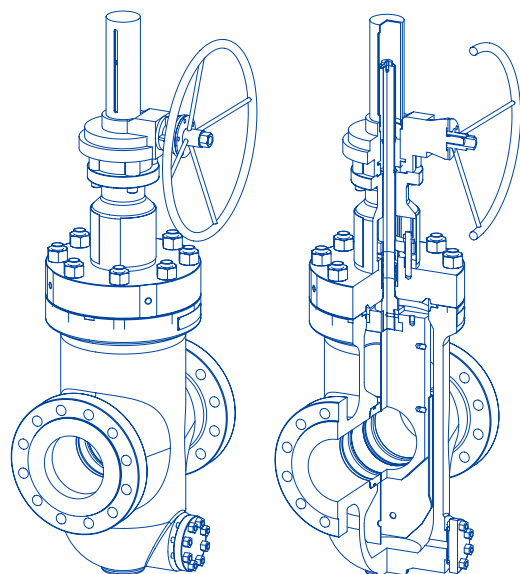

BEL Valves' reputation as a world leading supplier has been forged on the success of the Through Conduit Gate Valve, a product first supplied in the mid-1980s. With thousands of installations throughout all oil and gas bearing regions in the world, the product is synonymous for high performance and reliability.

## BENEFITS

- Corrosion resistant
- Fast closure
- Fire safe
- Gas tight sealing
- Inherently fail safe

## APPLICATIONS

Boarding skid, FPSO, HIPPS, HP/HT, isolation, metering skids, mooring systems, pig launching and receiving, pipeline, production platform, onshore receiving terminal.

## SPECIFICATIONS

Pressure rating	ANSI 150 to 2,500 API 2,000 to 15,000 psi
Temperature	-100°C to +190°C
Bore sizes	½" to 56"+
Material options	Carbon steel, low alloy steel, stainless steel, duplex, super duplex and inconel
Actuation	Manual, ROV, hydraulic (FSC, FAI, FSO), electric, pneumatic
Standards	API 6A, API 6D, API 6AV1, ISO 10423, ISO 14313

## CONFIGURATIONS

- Cast, forged or fabricated body
- Compact design option
- Full or reduced bore
- Rising or non-rising stem (outside or inside screw)
- Metal-to-metal or soft sealing
- Single or double block
- Various end connection options

## FEATURES

- On-off
- Tungsten carbide hard facing

